

CATALOGUE

Mopeds



MALOSSSI

INDEX

HONDA - PUCH - SUZUKI - YAMAHA

TABLES BRAND / MODEL	40
----------------------	----

MBK - PEUGEOT

CYLINDER KIT	32
CRANKCASE	37
TABLES BRAND / MODEL	30
VARIOTOP	38
VAR PLUS	39

PIAGGIO

POWER IGNITION	16
CRANKSHAFT	15
PIAGGIO CRANKCASE	10
CIAO (exploded)	4
BEARINGS	24
CYLINDER KIT	18
CARBURETTOR KIT	21
GEARS H.T.Q.	22
EXHAUST SYSTEM TOO BAD DEPS	27
VARIATOR MULTIVAR	25
OIL-SEAL	23
PULLEY	26
TABLES BRAND / MODEL	8

SECTIONALS

PLUGS	46
STICKERS FOLDERS	46
JET HELMETS	45
WORK GLOVES	46
GRIPS	44
LUBRICANTS	42

Malossi reserves the right to make technical, code, price modifications whenever it is considered necessary, and shall not accept liability for any typographic or printing errors.

Prices EXCL. TAX



4 Aluminium CYLINDER KIT Ø 47
pin Ø 10 BIG D.E.P.S.
31 7522 € 268,54

pin Ø 12 BIG D.E.P.S.
31 7524 € 268,54

 **Attention: bore the crankcase**

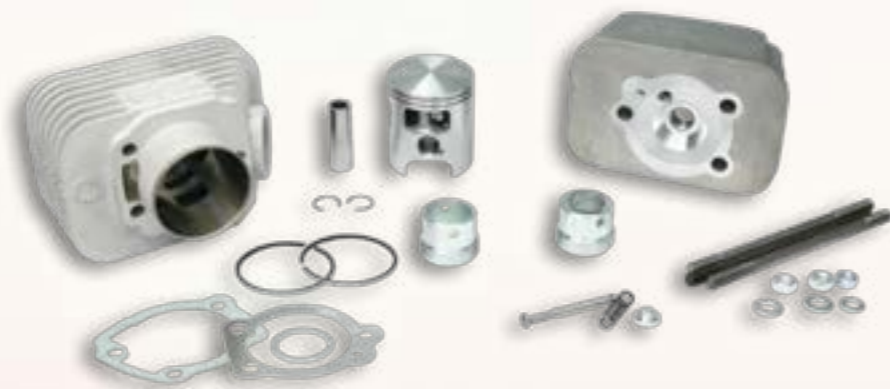

Cast-iron CYLINDER KIT Ø 46,5
pin Ø 10
31 6156 € 125,00

pin Ø 12
31 6157 € 125,00

 **Attention: bore the crankcase**



PRIMARY GEARS HTQ
(ONLY FOR vehicles WITH VARIATOR)
67 7021 € 139,74

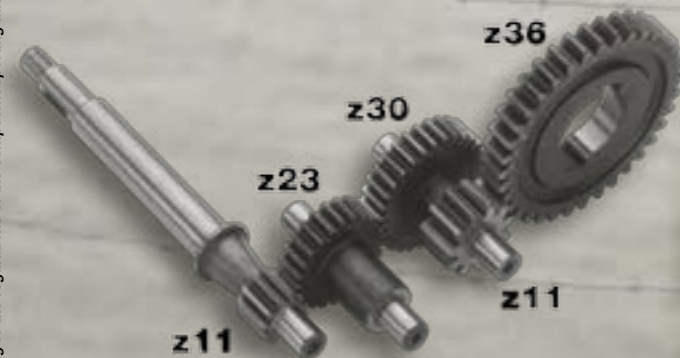

EXHAUST SYSTEM TOO BAD
ONLY for BIG DEPS CYLINDERS
with OVERSIZED FIXING Ø 27
3215442 € 130,00

OIL-SEAL
Ø 15x24x5 mm
FKM/PTFE crankshaft
Flywheel side
6615296B € 7,00



MULTIVAR PIAGGIO
motorcycles
51 3863 € 67,00



CLUTCH SPRINGS SET
(FOR vehicles WITH VARIATOR)
29 7307 € 15,70



ORIGINAL VARIATOR
ADJUSTER SPRING
RED - RACING
29 6955.R0 € 8,00
YELLOW - REINFORCED
29 7009.Y0 € 6,50

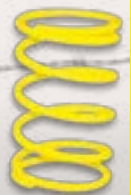
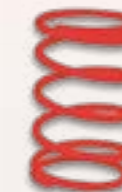

X K belt for variator
(13x6,5x974 mm 30°)
6116830 € 27,50



CRANKSHAFT HCP PIAGGIO motorcycles
pin Ø 10 53 7313 € 182,03
pin Ø 12 53 1802 € 182,03



2 ROLLER BEARINGS WITH BALLS
Ø 15x35x11 (STD) for crankshaft
66 4678E € 17,68



Ciao



Products to be used exclusively for racing in places specially designed for such activity according to the regulations of the competent sporting authorities. We accept no liability resulting from improper use.



Cast-iron CYLINDER KIT Ø 43
pin Ø 10 BASE+CVF
31 5116 € 125,00

pin Ø 12 BASE+CVF
31 5117 € 125,00

PIAGGIO CRANKCASE
5717892 € 183,00

NEW



CLUTCH SPRINGS SET
(ONLY FOR vehicles
WITHOUT VARIATOR)
29 7306 € 14,00



CLUTCH SHOES
AUTOMATIC MOTORCYCLES
without variator
52 7005 € 24,99



Impianto Alimentazione
SHA 13
1610866 € 51,45



DRIVEN PULLEY
€ 9,00

Ø 65 - **61 3548B**
 Ø 70 - **61 3538B**
 Ø 80 - **61 7280B**



EXHAUST SYSTEM
TOO BAD
3214894 € 126,00



X SPECIAL belt
for pulley Ø 70 (10x8x927 mm 36°)
61 7224 € 12,90

for pulley Ø 80 (10x8x940 mm 36°)
61 7226 € 12,90

Prices EXCL. TAX

MALOSSSI
 1957 2017
2015

VINTAGE CHARM WITH THE PIAGGIO CIAO

Since 2015, we have been convinced that vintage is not just a passing fad, but a trend that will stand the test of time (starting in 2008).

The orders for parts for models like the Piaggio Ciao have reached significant levels, a sign of the love by a niche group of enthusiasts for this vehicle that have made history.

In 1989, Malossi offered a highly innovative component for the Piaggio Ciao, which went down in history: the complete engine casing with reed valve.

The most difficult challenge was adapting the space of the original rotating induction unit with a reed valve that needed more space.

Having succeeded in doing this, Malossi placed itself in the market as a leading producer of parts for these scooters.

But we have done much more: we have gifted the Piaggio Ciao with determination and character by inserting a 19mm carburettor (instead of the original 10 mm).

The motor crank case produced by Malossi has turned out to be, over the years, highly durable as well as high performance.

Henry Favre can testify to this, Malossi's globetrotting friend, who over the years has put his Piaggio Ciao to the test in the extreme - such as his recent coast-to-coast trip of the United States - all thanks to the reliability of the components installed.

There are many races of enthusiasts that who still today race with "Ciao" and "Si" (such as the Monferraglia), and Malossi has always ensured that anyone who has the passion for these rides has all the components they need to continue racing at their disposal.



















MALOSSI

Piaggio Mopeds

with ENGINE 

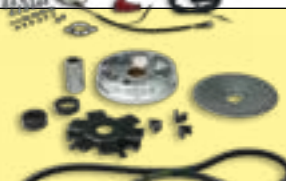
PIAGGIO			
BOSS	BRAVO	CIAO	CIAO PX

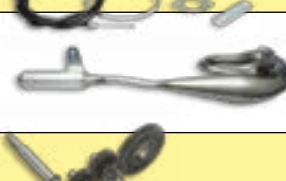
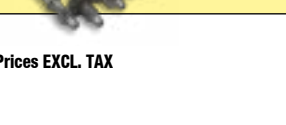

 ATTENTION: BORE THE CRANKCASE

		50 	50 	50 	50 
	CYLINDER+HEAD Ø 43	31 5490	31 5490	31 5116	31 5116
	CAST-IRON	€ 125,00	€ 125,00	€ 125,00	€ 125,00
	CYLINDER+HEAD  Ø 46,5	31 6158	31 6158	31 6156	31 6156
	CAST-IRON	€ 125,00	€ 125,00	€ 125,00	€ 125,00
	CYLINDER+HEAD BIG D.E.P.S.  Ø 47	31 7523	31 7523	31 7522	31 7522
	ALUMINIUM	€ 268,54	€ 268,54	€ 268,54	€ 268,54
	CYLINDER+HEAD Ø 43	31 5491	31 5491	31 5117	31 5117
	CAST-IRON	€ 125,00	€ 125,00	€ 125,00	€ 125,00
	CYLINDER+HEAD  Ø 46,5	31 6159	31 6159	31 6157	31 6157
	CAST-IRON	€ 125,00	€ 125,00	€ 125,00	€ 125,00
	CYLINDER+HEAD  Ø 47	31 7525	31 7525	31 7524	31 7524
	ALUMINIUM	€ 268,54	€ 268,54	€ 268,54	€ 268,54
	CRANKCASE	5717514	5717514	5717514	5717514
	ELECTRONIC COIL	€ 183,00	€ 183,00	€ 183,00	€ 183,00
	CRANKCASE	5717892	5717892	5717892	5717892
	MAGNETO POINTS COIL	€ 183,00	€ 183,00	€ 183,00	€ 183,00
	CRANKSHAFT PIN Ø 10	53 7313	53 7313	53 7313	53 7313
	FOR MALOSSI CRANKCASE	€ 182,03	€ 182,03	€ 182,03	€ 182,03
	CRANKSHAFT PIN Ø 12	53 1802	53 1802	53 1802	53 1802
	FOR MALOSSI CRANKCASE	€ 182,03	€ 182,03	€ 182,03	€ 182,03
	RADIAL BALL BEARINGS	66 4678E	66 4678E	66 4678E	66 4678E
	FOR CRANKSHAFT	€ 17,68	€ 17,68	€ 17,68	€ 17,68
	POWER IGNITION	5517192	5517192	5517192	5517192
		€ 310,00	€ 310,00	€ 310,00	€ 310,00
	MULTIVAR	51 3863	51 3863	51 3863	51 3863
	VARIATOR	€ 67,00	€ 67,00	€ 67,00	€ 67,00
	X K BELT BELT	6117006	6117005	6116830	6116830
	FOR VARIATOR	€ 31,00	€ 29,50	€ 27,50	€ 27,50
	X SPECIAL BELT BELT	61 7314	61 7223	61 7227	61 7227
	ONLY FOR VEHICLES WITH VARIATOR	€ 17,50	€ 13,16	€ 12,90	€ 12,90
	HTRoll	66 9823.L0	66 9823.L0	66 9823.L0	66 9823.L0
	ROLLERS FOR MULTIVAR	€ 9,98 gr.06	€ 9,98 gr.06	€ 9,98 gr.06	€ 9,98 gr.06
	VARIATOR ADJUSTER SPRING	29 7009.Y0 € 6,50	29 7009.Y0 € 6,50	29 7009.Y0 € 6,50	29 7009.Y0 € 6,50
	SPORT / MHR	29 6955.R0 € 8,00	29 6955.R0 € 8,00	29 6955.R0 € 8,00	29 6955.R0 € 8,00
	CLUTCH SHOE SET	52 7005	52 7005	52 7005	52 7005
	FOR VEHICLES WITHOUT VARIATOR	€ 24,99	€ 24,99	€ 24,99	€ 24,99
	SPRING SET FOR CLUTCH	29 7306	29 7306	29 7306	29 7306
	FOR VEHICLES WITHOUT VARIATOR	€ 14,00	€ 14,00	€ 14,00	€ 14,00
	SPRING SET FOR CLUTCH	29 7307	29 7307	29 7307	29 7307
	FOR VEHICLES WITH VARIATOR	€ 15,70	€ 15,70	€ 15,70	€ 15,70
	PULLEY Ø 80	-	-	61 7280B	61 7280B
				€ 9,00	€ 9,00
	X SPECIAL BELT BELT	-	-	61 7226	61 7226
	FOR PULLEY			€ 12,90	€ 12,90
	PULLEY Ø 70	-	-	61 3538B	61 3538B
				€ 9,00	€ 9,00
	X SPECIAL BELT BELT	-	-	61 7224	61 7224
	FOR PULLEY			€ 12,90	€ 12,90
	PULLEY Ø 70	-	-	61 3548B	61 3548B
				€ 9,00	€ 9,00
	PULLEY Ø 65	-	-	61 3548B	61 3548B
				€ 9,00	€ 9,00
	CARBURETTOR KIT SHA 13	1610869	1610867	1610866	1610870
		€ 51,45	€ 47,45	€ 51,45	€ 51,45
	CARBURETTOR KIT PHBG 19	1610989	1610989	1610989	1610989
	FOR MALOSSI CRANKCASE	€ 202,63	€ 202,63	€ 202,63	€ 202,63
	TOO BAD	3214893	3214894	3214894	3214894
	EXHAUST SYSTEM	€ 126,00	€ 126,00	€ 126,00	€ 126,00
	TOO BAD EXHAUST SYSTEM ONLY FOR	3215438	3215442	3215442	3215442
	CYLINDER BIG D.E.P.S. (Clutch In Ø 27)	€ 130,00	€ 130,00	€ 130,00	€ 130,00
	PRIMARY GEARS HTQ	67 7021	67 7021	67 7021	67 7021
	FOR VEHICLES WITH VARIATOR	€ 139,74	€ 139,74	€ 139,74	€ 139,74

Products to be used exclusively for racing in places specially designed for such activity according to the regulations of the competent sporting authorities. We accept no liability resulting from improper use.

Prices EXCL. TAX

PIAGGIO		
GRILLO	SI	SUPERBRAVO

	50 	50 	50 
31 5490	31 5490	31 5490	31 5490
€ 125,00	€ 125,00	€ 125,00	€ 125,00
31 6158	31 6158	31 6158	31 6158
€ 125,00	€ 125,00	€ 125,00	€ 125,00
31 7523	31 7523	-	-
€ 268,54	€ 268,54	-	-
31 5491	31 5491	31 5491	31 5491
€ 125,00	€ 125,00	€ 125,00	€ 125,00
31 6159	31 6159	31 6159	31 6159
€ 125,00	€ 125,00	€ 125,00	€ 125,00
31 7525	31 7525	-	-
€ 268,54	€ 268,54	-	-
5717514	5717514	5717514	5717514
€ 183,00	€ 183,00	€ 183,00	€ 183,00
5717892	5717892	5717892	5717892
€ 183,00	€ 183,00	€ 183,00	€ 183,00
53 7313	53 7313	53 7313	53 7313
€ 182,03	€ 182,03	€ 182,03	€ 182,03
53 1802	53 1802	53 1802	53 1802
€ 182,03	€ 182,03	€ 182,03	€ 182,03
66 4678E	66 4678E	66 4678E	66 4678E
€ 17,68	€ 17,68	€ 17,68	€ 17,68
5517192	5517192	5517192	5517192
€ 310,00	€ 310,00	€ 310,00	€ 310,00
51 3863	51 3863	51 3863	51 3863
€ 67,00	€ 67,00	€ 67,00	€ 67,00
-	6117006	6117005	-
	€ 31,00	€ 29,50	
61 7222	61 7314	61 7223	61 7223
€ 12,60	€ 17,50	€ 13,16	€ 13,16
66 9823.L0	66 9823.L0	66 9823.L0	66 9823.L0
€ 9,98 gr.06	€ 9,98 gr.06	€ 9,98 gr.06	€ 9,98 gr.06
29 7009.Y0 € 6,50	29 7009.Y0 € 6,50	29 7009.Y0 € 6,50	29 7009.Y0 € 6,50
29 6955.R0 € 8,00	29 6955.R0 € 8,00	29 6955.R0 € 8,00	29 6955.R0 € 8,00
52 7005	52 7005	52 7005	52 7005
€ 24,99	€ 24,99	€ 24,99	€ 24,99
29 7306	29 7306	29 7306	29 7306
€ 14,00	€ 14,00	€ 14,00	€ 14,00
29 7307	29 7307	29 7307	29 7307
€ 15,70	€ 15,70	€ 15,70	€ 15,70
-	-	-	-
-	-	-	-
-	-	-	-
-	-	-	-
-	-	-	-
1610869	1610869	1610867	1610867
€ 51,45	€ 51,45	€ 47,45	€ 47,45
1610989	1610989	1610989	1610989
€ 202,63	€ 202,63	€ 202,63	€ 202,63
3214893	3214893	-	-
€ 126,00	€ 126,00	-	-
3215438	3215438	-	-
€ 130,00	€ 130,00	-	-
67 7021	67 7021	67 7021	67 7021
€ 139,74	€ 139,74	€ 139,74	€ 139,74



MP-DNE CRANK CASE

The Piaggio Ciao motor, assembled with our components, is so attractive that it almost resembles a work of art! The sound produced by this motor is music to the ears of our designer Gianluca!

Gianluca Bini



MALOSSSI



NEW**CARTER MP-ONE**

Pressure die-cast, shot-blasted crankcase in aluminium-silicon alloy. Complete Malossi project with lamellar intake, controlled by a reed valve with four petals.

Available in 2 versions which include the entire range of Piaggio and Gilera motorbikes:

Electronic ignition - 5717514 € 183,00

Magneto ignition - 5717892 € 183,00

They can be used with any cylinder kit, exhaust system, crankshaft and fuel system.

PIAGGIO BOSS
BOXER
BRAVO
CIAO
CIAO PX
GRILLO
SI
SUPERBRAVO



Malossi lamellar crankcases are fully compatible with the original ones and are fitted with a special inlet manifold for the original carburettor or a SHA 13/13 carburettor.



A specific fuel system has been developed with a 19-mm carburettor and type E12 air filter, including all the details for assembly.

1610989

€ 202,63

Carburettor kit PHBG 19 B



MALOSSİ

NEW**CARTER MP-ONE**

Due to the restricted assembly space on Piaggio frames, an ultra-compact engine had to be developed. Once again, our technicians passed the test with flying colours. The goals reached are: a highly technical product with a sturdy, simple, easy-to-assemble design; resulting in exceptional operation with no need for modifications (everything is connected in the same way as the original engine). The 4-petal composite fibre reed valve guarantees a regular, steady intake which optimises the torque curve, starting from lower rpm and allowing maximum power output.

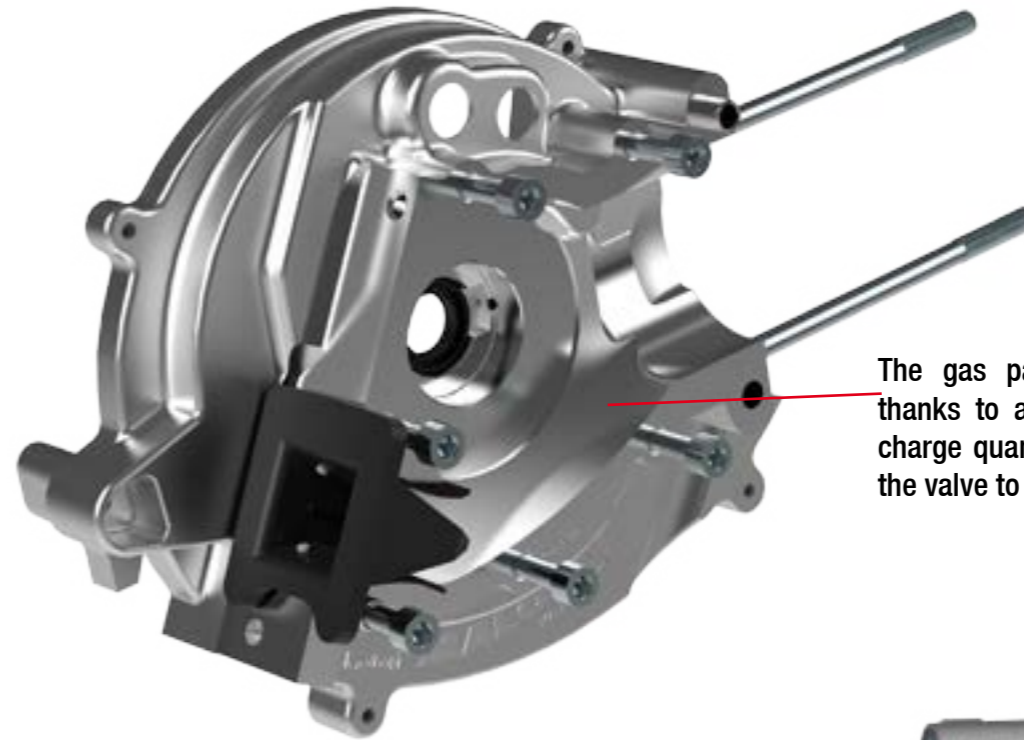

The gas passage has been totally revised thanks to a pipe which can grant a greater charge quantity together with less leaks from the valve to the cylinder.

The introduction of two new gas slides under lets the crankcase be better connected to high performing cylinders.

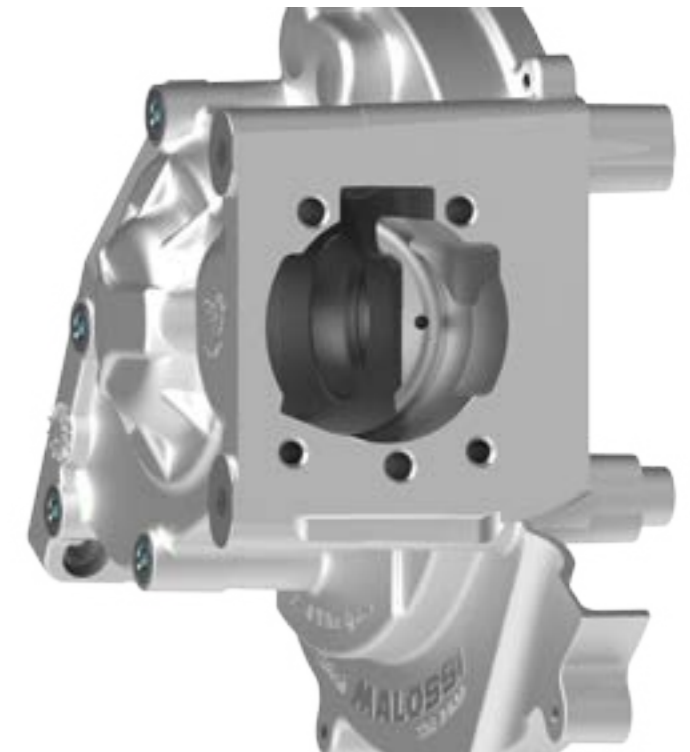

MALOSSİ

NEW

CARTER MP-ONE

The new spiral case constrains gas to do a calculated route much more addressed to the cylinder cooling fins thus warranting the cylinder kit functioning at the best rpm even in the heaviest conditions.

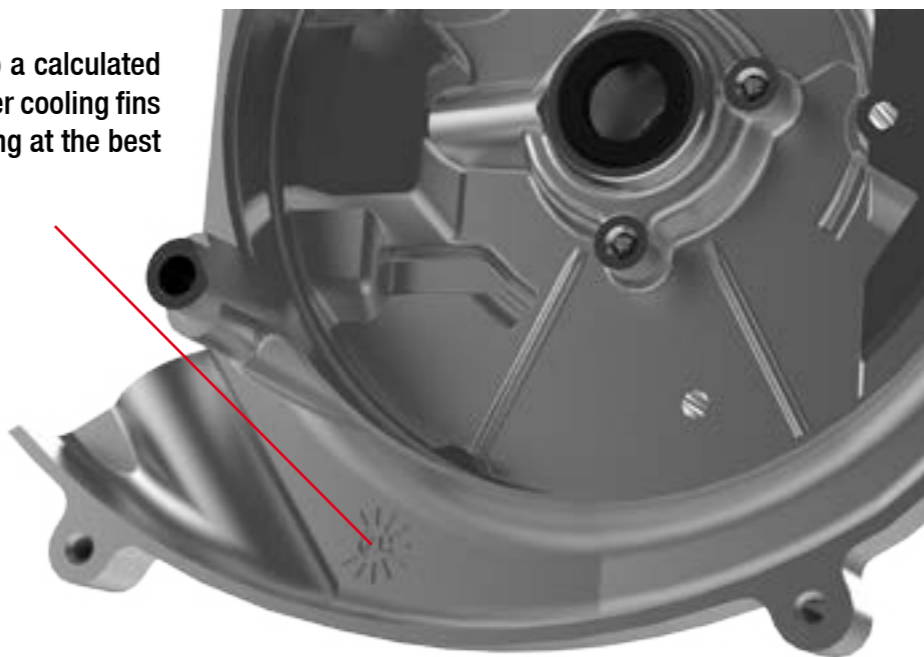

Crankcase fitting is now easier thanks to a high precision centering achieved by means of both calibrated bushings and newest slots whose housings totally incorporate the cylindrical head screws which can be screwed by a simple Allen key.

In order to achieve remarkable torque and power values, the structure has been entirely strengthened with specific shims in the more stressed parts.

The Malossi project makes the work of mechanics easier, but still leaves large space to the imagination of two-stroke motorcycle fans who want to showcase their technical skills.



Products to be used exclusively for racing in places specially designed for such activity according to the regulations of the competent sporting authorities. We accept no liability resulting from improper use.

Prices EXCL. TAX



MALOSSİ

CRANKSHAFTS R.H.Q.

pin Ø 12 - **53 1802 € 182,03**
 pin Ø 10 - **53 7313 € 182,03**



PIAGGIO BOSS
 BRAVO
 CIAO
 CIAO PX
 GRILLO
 SI
 SUPERBRAVO

PIAGGIO

TECHNICAL SPECIFICATIONS

- Half-shafts material: 18 Ni Cr Mo5.
- Half-shafts with forged monolithic rotating masse.
- Manufactured using high-precision machine tools.
- All components are subjected to 5 heating treatment operations.
- Excellent surface finish for improved reliability.
- Dynamic balancing for speeds of up to 16,000 rpm.
- Coppered connecting rod in forged 18 Ni Cr Mo5, connected to the engine with precision roller bearing for high speeds.

- The crankshaft is the heart of the endothermic engine.
- All aspects of engine performances start from the crankshaft.
- It is not possible to obtain good engine performance and reliability unless a top-quality crankshaft is fitted.
- This is why Malossi produces only the very best in crankshafts.

27 5610.K0 € 8,10

4 Karbonit fiber petals

2 thick. 0,30/0,35

VL7/VL8 for MALOSSİ CRANKCASE



PIAGGIO BOSS
 BRAVO
 CIAO
 CIAO PX
 GRILLO
 SI
 SUPERBRAVO

NEW**MALOSSI***Ciao***Power Ignition****5517192 € 310,00**

PIAGGIO BOSS
BRAVO
CIAO
CIAO PX
GRILLO
SI
SUPERBRAVO



When preparing motors, ignition usually gets secondary attention. Yet this component is of vital importance since it is the one that manages the exact moment in which to ignite the spark on the glow plug and regulates the amount of current that determines the quality of the spark in order to obtain optimal combustion. Both in prepared and original engines, replacement with a newer and more performing ignition is an operation that can breathe new life into the engine itself and allows for more efficient and simple fine tuning.

Malossi and its team of engineers are proud to announce **Power**, the 12 Volt electronic ignition for the entire family of Piaggio motor bikes which originally features electronic ignition.

This ignition, which is the top in its category, is distinguished by its easy assembly, typical of a plug & play product. In fact, the kit includes everything that could be needed for proper assembly and immediate use.

In the **Power** package, you will find everything you need:

- Adapter ring to correctly attach the stator to the casing!
- 12 Volt (90 watt) 4 pole stator. It IS necessary to change all of the original bulbs!
- Light flywheel (885 g for a 16.2 kg/cm² moment of inertia) hot moulded and designed to resist the highest amount of rotations!
- Red plastic fan!
- Ready to use wiring with output cable for battery charging or stereo connection, for original modifications!
- Voltage regulator!



With this kit, your Ciao will be hungry for laps and opponents on the track. **Power** ignites your passion!

Prices EXCL. TAX

POWER**MALOSSI**

Aluminium CYLINDER KIT

Malossi BIG D.E.P.S.



• The picture refers to art. 31 7522

Mopeds PIAGGIO 50	Aluminium cylinder kit			
	Ø 47 pin Ø 10		Ø 47 pin Ø 12	
	Code	Price	Code	Price
BOSS	31 7523	€ 268,54	31 7525	€ 268,54
BRAVO	31 7523	€ 268,54	31 7525	€ 268,54
CIAO	31 7522	€ 268,54	31 7524	€ 268,54
CIAO PX	31 7522	€ 268,54	31 7524	€ 268,54
GRILLO	31 7523	€ 268,54	31 7525	€ 268,54
SI	31 7523	€ 268,54	31 7525	€ 268,54



ATTENTION:
BORE THE CRANKCASE



Prices EXCL. TAX

Ciao



After much success with Piaggio crankcases, Malossi completes the task: Aluminium Ø47 BIG D.E.P.S. Cylinder and Head Kits are now available again!

The only CIAO/SI cylinders on the market with a split exhaust port and symmetrical transfer ports!!!

Threaded type exhaust header offers two major advantages:

- Increased strength and the possibility for replacement due to failure.
- Possibility to increase the exhaust size hence increasing the performance.

These results are possible due to a smaller decompression valve, compared to the Piaggio original, which is supplied with the kit.

Centred, hemispherical combustion chamber.

Malossi aluminium BIG D.E.P.S. cylinder kits are the best balance between component performance and component durability! The BIG D.E.P.S. are designed and manufactured with the specific objective of obtaining high combustion efficiency, long life, and a reliability that suits the Malossi name.

Owing to the experience gained in the preparation of cylinder kits for racing, Malossi engineers have developed the thermodynamics of the aluminium cylinder kit to the fullest and designed the inner fluid mechanics of the cylinder kit with fanatical precision (see the transfer ports, exhaust and combustion chamber), thereby obtaining a high level of turbulence in the combustion chamber. The latter has permitted a substantial reduction in consumption and a drastic reduction in exhaust emission pollutants.

Technical data

- Split exhaust port.
- Symmetrical transfer ports.
- Centred, hemispherical combustion chamber.
- Smaller decompression valve.
- Six transfer porting system.
- Gravity casted cylinders utilizing permanent steel molds.
- Hardened and tempered high silicon aluminium alloy.
- Machined on numerically controlled high precision machining centres.
- Cylinder liners are silicon carbide coated with a galvanic nickel matrix and diamond cross-honed to achieve very tight tolerances.
- Heat exchange surfaces redesigned.
- Exhaust and transfer ports designed and tested for maximum thermodynamic performance.
- High strength cast iron rings, wear resistant chrome coated, ground and lapped.
- Quality inspected for surface roughness and form.
- Cylinder/ Piston matched sets selected for 0.010-0.005 mm fit.
- 100% pressure checked.
- 2 exhaust connectings: oversized Ø 27 - standard Ø 22.

Cylinder and head kit BIG D.E.P.S.: the perfect match for Malossi's crankcase!

Code	31 7522	31 7523	31 7524	31 7525
	Ø 47 mm	Ø 47 mm	Ø 47 mm	Ø 47 mm
Stroke	43 mm	43 mm	43 mm	43 mm
Capacity	74,6	74,6	74,6	74,6
Compression ratio	12,5:1	12,5:1	12,5:1	12,5:1
Cooling	Air	Air	Air	Air
N° ports	7	7	7	7
Spark plug SPORT	IRIDIUM IW F 24	IRIDIUM IW F 24	IRIDIUM IW F 24	IRIDIUM IW F 24
Spark plug MHR	IRIDIUM IW F 27	IRIDIUM IW F 27	IRIDIUM IW F 27	IRIDIUM IW F 27

Cast-iron CYLINDER KIT



• The picture refers to art. 31 5490

Malossi cast iron cylinder kits, the first and simplest step to modifying your moped engine, are the best choice to be matched to a standard or homologated exhaust system.

These cylinder kits combine the high durability of cast iron with the almost maniacally high quality standards of Malossi, one of the few companies demanding the most even from this class of cylinder kits.

The most rigid selections for matching cylinder and piston, strictly maintained within a tolerance range of max 20 microns, shall be seen in this perspective as well.

Depending on their application, Malossi cast iron cylinder kits are provided with the specific head and O-ring, or they can be mounted with the original head without any modifications for air-cooled vehicles.

Mopeds PIAGGIO 50	Cast-iron cylinder kit							
	Ø 43 pin Ø 10		Ø 43 pin Ø 12		Ø 46,5 pin Ø 10		Ø 46,5 pin Ø 12	
	Code	Price	Code	Price	Code	Price	Code	Price
BOSS	31 5490	€ 125,00	31 5491	€ 125,00	31 6158	€ 125,00	31 6159	€ 125,00
BRAVO	31 5490	€ 125,00	31 5491	€ 125,00	31 6158	€ 125,00	31 6159	€ 125,00
CIAO	31 5116	€ 125,00	31 5117	€ 125,00	31 6156	€ 125,00	31 6157	€ 125,00
CIAO PX	31 5116	€ 125,00	31 5117	€ 125,00	31 6156	€ 125,00	31 6157	€ 125,00
GRILLO	31 5490	€ 125,00	31 5491	€ 125,00	31 6158	€ 125,00	31 6159	€ 125,00
SI	31 5490	€ 125,00	31 5491	€ 125,00	31 6158	€ 125,00	31 6159	€ 125,00
SUPERBRAVO	31 5490	€ 125,00	31 5491	€ 125,00	31 6158	€ 125,00	31 6159	€ 125,00

Technical features

Code	31 5116 Ø 43 mm	31 5490 Ø 43 mm	31 5117 Ø 43 mm	31 5491 Ø 43 mm	31 6157 Ø 46,5 mm	31 6158 Ø 46,5 mm	31 6156 Ø 46,5 mm	31 6159 Ø 46,5 mm
Stroke	43 mm	43 mm	43 mm	43 mm	43 mm	43 mm	43 mm	43 mm
Capacity	62,4	62,4	62,4	62,4	73	73	73	73
Compression ratio	01:13	01:13	01:13	01:13	01:12	01:12	01:12	01:12
Cooling	Air	Air	Air	Air	Air	Air	Air	Air
N° ports	6	6	6	6	6	6	6	6
Spark plug SPORT	IRIDIUM IW F 24	IRIDIUM IW F 24	IRIDIUM IW F 24	IRIDIUM IW F 24	IRIDIUM IW F 24	IRIDIUM IW F 24	IRIDIUM IW F 24	IRIDIUM IW F 24
Spark plug MHR	IRIDIUM IW F 27	IRIDIUM IW F 27	IRIDIUM IW F 27	IRIDIUM IW F 27	IRIDIUM IW F 27	IRIDIUM IW F 27	IRIDIUM IW F 27	IRIDIUM IW F 27

Prices EXCL. TAX

Carburettor kit SHA 13



These systems have been specially designed and calibrated for high-performance motors, and are complete with all accessories needed for assembly (see general catalogue). MALOSSI is the leader in the design and production of special fuel systems for motorcycles and scooters.

MALOSSI systems are the result of intense research and precision drawings and calculations. The suction pipes, reed valves, and air intakes designed by MALOSSI undergo efficiency tests and destructive tests to check their performance and reliability.

Carburetors are customized for each vehicle according to the specific characteristics of the motor and air intake, and are completely calibrated for dosage of the air-fuel mixture under all power delivery conditions.

MALOSSI produces special components for fuel systems in order to supply a product that responds perfectly to the needs of the most demanding customer.

Mopeds PIAGGIO 50	Carburettor kit SHA 13	
	Code	Price
BOSS	1610869	€ 51,45
BRAVO	1610867	€ 47,45
CIAO	1610866	€ 51,45
CIAO PX	1610870	€ 51,45
GRILLO	1610869	€ 51,45
SI	1610869	€ 51,45
SUPERBRAVO	1610867	€ 47,45



Primary gears H.t.q. (Only for vehicles with variator)

67 7021 € 139,74

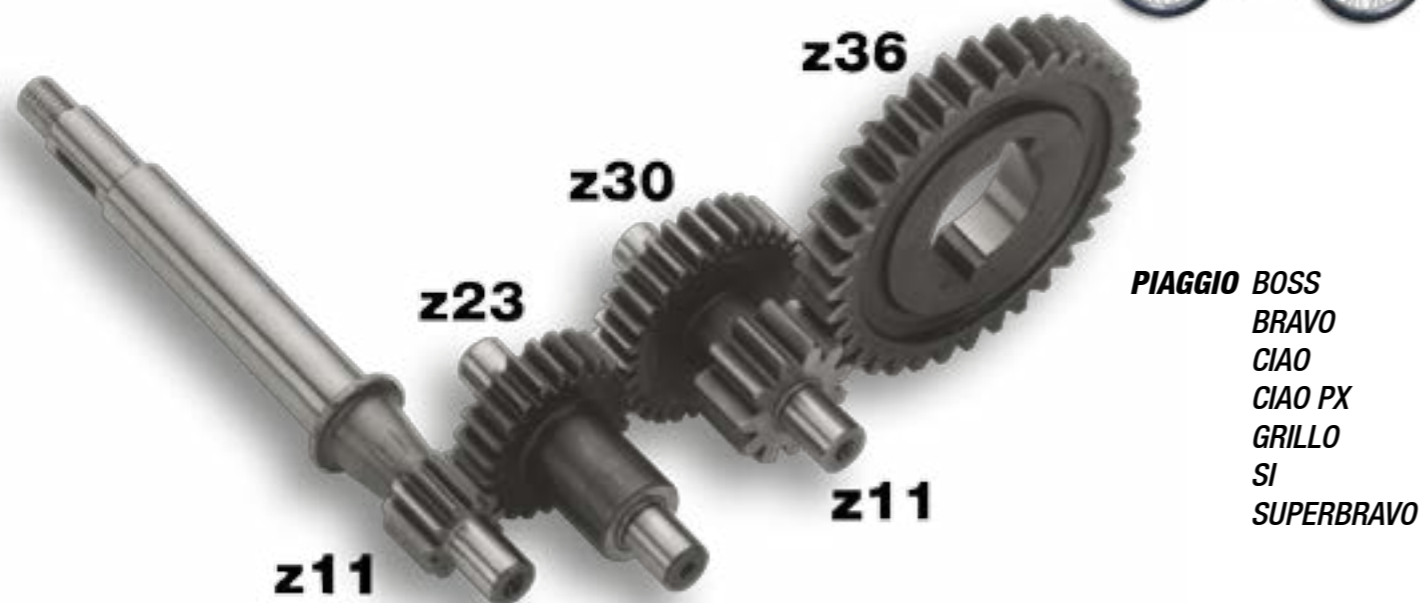

Malossi S.p.A. is pleased to offer its new series of final transmission gears.

These new gears were created by exploiting our 20-year experience in designing and building gears. The new H.t.q. gears were designed and built with straight / helical teeth to minimise losses through friction and stress on the supports. Moreover, our gears increase ratios slightly enabling you to exploit the full power of your vehicle, thus significantly increasing its original performance potential.



Products to be used exclusively for racing in places specially designed for such activity according to the regulations of the competent sporting authorities. We accept no liability resulting from improper use.

Prices EXCL. TAX

OIL-SEAL FKM plus PTFE



Responding to the requests of our exacting customers, Malossi proudly offers a new product line of engine oil seals for scooters, filling a void in the market.

Oil seals with special characteristics, high quality for racing, with low rotational friction and high durability.



FKM plus PTFE oil seals boast the highest quality materials and advanced material technology ensuring product quality which is, as always, the driving force and pride behind Malossi.

In presenting this new product to our esteemed enthusiasts, Malossi, in the hope of achieving its desired goal, would like to thank its customer's loyalty to the brand.

Technical Characteristics

- 1) Oil seal's body primarily constructed of a special mix of synthetic rubber and fluoropolymer elastomers (FKM).
- 2) Support structure consists of a carbon steel armature, encapsulated with FKM.
- 3) Internal seal design consists of an auxiliary dust lip and primary sealing lip made of PTFE, a material with a low coefficient of friction and high wear resistance.
- 4) Stainless steel internal spring, designed to maintain constant pressure on the rotating shaft.

mm	OIL-SEAL SET FKM / PTFE	
	for OVERHAUL	for CRANKSHAFT

MOPEDS 50				
PIAGGIO CIAO - BRAVO - SI				
Crankshaft (flywheel side)	Ø 15x24x5		6615296B	 € 7,00
Crankshaft (flywheel side)	Ø 15x24x5		6617382B	 € 4,50

Special high-precision bearings

High-speed bearings with increased load capacity, designed and tested for endothermic racing engines.

Special high-speed precision bearings, reinforced for increased load and heavy applications, with oversize balls, carbonitrided inner rings, steel and polyamide cages. The co-operation of Malossi technicians with the company SKF allowed to obtain an important technical result for the fine-tuning of high-quality racing engines.

The column of technical specifications bears an abbreviation which indicates the main technical features of each bearing.



CRANKSHAFT BEARING							PRICE
SIZE	TYPE	Ø BALL	CLEARANCE	CAGE	CODE		
PIAGGIO - CIAO - BRAVO - SI - BOXER 50							
1 BEARING	15X35X11	SFERE	6	STD	STEEL	66 4678B	€ 8,93
2 BEARINGS	15X35X11	SFERE	6	STD	STEEL	66 4678E	€ 17,68
1 BEARING	15X35X11	X SFERE	6	C3	STEEL	6616872B	€ 11,00
2 BEARINGS	15X35X11	X SFERE	6	C3	STEEL	6616872E	€ 21,78

X = Carbonitrided inner ring.
 K = Carbonitrided inner ring, oversize balls and special reduced outer ring.



Prices EXCL. TAX

Products to be used exclusively for racing in places specially designed for such activity according to the regulations of the competent sporting authorities. We accept no liability resulting from improper use.

MULTIVAR

51 3863 € 67,00

PIAGGIO BOSS
 BRAVO
 CIAO
 CIAO PX
 GRILLO
 SI
 SUPERBRAVO



Multivar is very easy to fit and to modify. It is developed in detail and for specific applications. With a variator that features such sophistication, your scooter has that extra sprint, a consistency in shifting, a greater mechanical ease at high speeds and a constancy in performance you've never experienced before with the original variator. This is what the Malossi technicians wanted to obtain.



Dekra Certification GmbH certifies that Malossi produces its complete variators and CVT-kits efficiently applying a quality management system, as required by the German and International road circulation law (KBA).

BELT for Variator



Mopeds	X SPECIAL BELT		X K BELT	
	Code	Price	Code	Price
PIAGGIO 50				
BOSS	61 7314	€ 17,50	---	---
BRAVO	61 7223	€ 13,16	---	---
CIAO	61 7227	€ 12,90	6116830	€ 27,50
CIAO PX	61 7227	€ 12,90	6116830	€ 27,50
GRILLO	61 7222	€ 12,60	---	---
SI	61 7314	€ 17,50	---	---
SUPERBRAVO	61 7223	€ 13,16	---	---

DRIVEN PULLEY

Ø 65 - **61 3548B** € 9,00

Ø 70 - **61 3538B** € 9,00

Ø 80 - **61 7280B** € 9,00

PIAGGIO CIAO
CIAO PX



BELT X SPECIAL BELT for Pulley

61 7224 € 12,90

for pulley Ø 70 (10x8x927 mm 36°)

61 7226 € 12,90

for pulley Ø 80 (10x8x940 mm 36°)

PIAGGIO CIAO
CIAO PX



Prices EXCL. TAX

Products to be used exclusively for racing in places specially designed for such activity according to the regulations of the competent sporting authorities. We accept no liability resulting from improper use.

TOO BAD DEPS

Malossi Power Exhaust

High Performance Exhaust Systems

Malossi is glad to present the new TOO BAD D.E.P.S. exhaust systems, specifically developed for Malossi BIG D.E.P.S. cylinder kits with mounting flange Ø 27! Two new projects designed for collectors and enthusiasts of high quality machines, for the legendary motorcycles that left its mark in history. The already outstanding cylinder kits, known as C.V.F., and the reed valve intakes were the focal points for the evolution of this motorcycle. Within Malossi, there was a strong desire to add to them a special series of exhausts: the new TOO BAD D.E.P.S. exhaust, sport exhaust systems, re-designed for high performance, with modern and aggressive styling. Innovation and creativity is part of Malossi's DNA, product improvement and constant development are our strong points, this is why our products are so long lasting and well remembered by our admirers.

For us, "Made in Italy" is our inspiration.

		FOR CYLINDERS BIG D.E.P.S. with oversize exhaust connection Ø 27		FOR CYLINDERS with standard exhaust connection Ø 22	
PIAGGIO	BRAVO	3215438	€ 130,00	3214893	€ 126,00
	BOSS	3215438	€ 130,00	3214893	€ 126,00
	CIAO	3215442	€ 130,00	3214894	€ 126,00
	CIAO PX	3215442	€ 130,00	3214894	€ 126,00
	GRILLO	3215438	€ 130,00	3214893	€ 126,00
	SI	3215438	€ 130,00	3214893	€ 126,00



TECHNICAL DATA

- Mounting flange and exhaust pipe Ø 27
- Exhaust system with add-on refurbishable silencer.
- Expansion chamber and brackets made of FeP04 steel
- Coated with high temperature resistant transparent paint
- Removable and repackable silencer with anodized aluminium housing
- Exhaust system includes a complete set of brackets, collars, screws and all parts needed for assembly, interchangeable with the original exhaust without need for modifications.



1980

The debut of the kits for Peugeot and Motobécane mopeds



Following the great success achieved with the products for enhancing the small Japanese motorcycle Yamaha TY in France and Northern Europe, Malossi carefully studied the French market in order to understand which models could become the new recipients of the special parts from Calderara di Reno. The choice fell on these two small mopeds which were very widespread mostly beyond the Alps because at the time each national state produced its own vehicles within its national borders: in Italy, in fact, Piaggio Ciao dominated the market. After about one year of research, the new kits were released. They consisted of the complete cylinder kit plus manifold and carburettor, as well as the exhaust (the "Anaconda" muffler shown in the picture). For the first time a new element was introduced, the reed valve, which was crucial to the future of the company's production and to the performance of these new mopeds. A new carburettor was added as well thanks to an established collaboration with Dell'Orto: at the explicit request of Malossi technicians they produced a carburettor with an increased maximum diameter of up to 15 mm which is still included in the current product range.



The sale of this kit in France was a great success thanks to the sales network already well-established in the country and thanks to consumer confidence in the Italian brand, which is why Malossi thought big: from the mid-80s onward, they released a crankshaft and a dedicated variator, the Variotop, which provisionally completed the transformation capabilities of this vehicle, transforming it into a jewel of technology and performance.



Thanks specifically to these vehicles, Malossi's research in the area of automatic transmissions began: a research that continued to develop positively in the decades that followed, making the company a world leader in the production of this component.

The product range dedicated to these vehicles continued to expand throughout the decade, concluding with the production of an electronic ignition and a complete engine crankcase. The success was real and contributed to the constant growth of the company, so much so that these components can still be found in the current Malossi catalogue.





























On the basis of the research experience gained in the production of special parts for these vehicles, the MVR project was developed. This was the first vehicle to be entirely designed and built at Calderara di Reno.

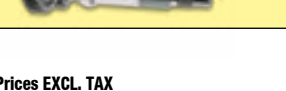

MALOSSI



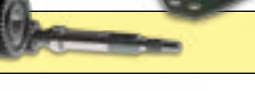







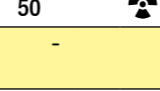

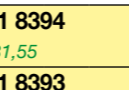
MBK – PEUGEOT Mopeds

with ENGINE 

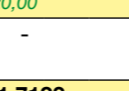
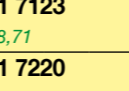
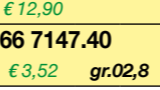
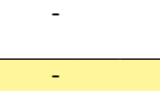
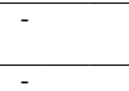
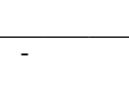
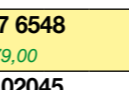
		MBK			
		51 V	MAGNUM	PASSION	RACING
		(AV 10)	(AV 10)	(AV 10)	(AV 10)
		50	50	50	50
	CYLINDER+HEAD LC Ø 39 - 40	31 5477 € 225,00 Ø 39	31 5477 € 225,00 Ø 39	31 5477 € 225,00 Ø 39	31 5477 € 225,00 Ø 39
	CYLINDER ALUMINIUM Ø 39 - 40	31 6864 € 171,85 Ø 39	31 6864 € 171,85 Ø 39	31 6864 € 171,85 Ø 39	31 6864 € 171,85 Ø 39
	HEAD WITH DECOMPRESSOR Ø 40	-	-	-	-
	HEAD WITHOUT DECOMPRESSOR Ø 40	-	-	-	-
	CYLINDER+HEAD LC Ø 45,5 WITH DECOMPRESSOR	-	-	-	-
	CYLINDER+HEAD LC Ø 45,5 WITHOUT DECOMPRESSOR	-	-	-	-
	CYLINDER ALUMINIUM Ø 45,5	31 3013 € 220,00	31 3013 € 220,00	31 3013 € 220,00	31 3013 € 220,00
	HEAD WITH DECOMPRESSOR Ø 45,5	38 5549 € 29,50 Ø 45,5	38 5549 € 29,50	38 5549 € 29,50	38 5549 € 29,50
	HEAD WITHOUT DECOMPRESSOR Ø 45,5	-	-	-	-
	CYLINDER CAST-IRON Ø 45,5	-	-	-	-
	CRANKSHAFT (PIN)	53 5779 € 202,00 Ø 13	53 5779 € 202,00 Ø 13	53 5779 € 202,00 Ø 13	53 5779 € 202,00 Ø 13
	MULTIVAR VARIATOR	-	-	-	-
	X SPECIAL BELT BELT	6112745 € 15,81	6112745 € 15,81	6112745 € 15,81	6112745 € 15,81
	HTRoll ROLLERS FOR MULTIVAR	-	-	-	-
	VARIABLE-SPEED DRIVE ADJUSTER SPRING SPORT / MHR	-	-	-	-
	VAR PLUS KIT	51 6798 € 33,12	51 6798 € 33,12	51 6798 € 33,12	51 6798 € 33,12
	VARIOTOP FOR VEHICLES WITH CLUTCH	-	-	-	-
	VARIOTOP FOR VEHICLES WITH CLUTCH (REVERSED FITTING))	51 7723 € 180,00	51 7723 € 180,00	51 7723 € 180,00	51 7723 € 180,00
	VARIOTOP FOR VEHICLES WITHOUT CLUTCH	51 6839 € 170,00	51 6839 € 170,00	51 6839 € 170,00	51 6839 € 170,00
	VARIOTOP FOR VEHICLES WITHOUT CLUTCH FOR ORIGINAL VARIATOR COVER	51 6921 € 180,00	51 6921 € 180,00	51 6921 € 180,00	51 6921 € 180,00
	CRANKCASE SET	-	-	-	-
	CARBURETTORS SHA 15/15	A02045 € 37,40	A02045 € 37,40	A02045 € 37,40	A02045 € 37,40
	PHBG 17,5	72 5741 € 86,24	72 5741 € 86,24	72 5741 € 86,24	72 5741 € 86,24
	PHBG 19,5	72 5742 € 86,24	72 5742 € 86,24	72 5742 € 86,24	72 5742 € 86,24
	CARBURETTOR KIT PHBG	-	-	-	-
	REED INTAKE-MANIFOLD SET Ø 15	-	-	-	-
	REED INTAKE-MANIFOLD SET Ø 21	-	-	-	-
	REED VALVE FOR ORIGINAL CRANKCASE	27 3021.K0 € 20,25 VL2	27 3021.K0 € 20,25 VL2	27 3021.K0 € 20,25 VL2	27 3021.K0 € 20,25 VL2
	GEARS HTQ PRIMARY	-	-	-	-

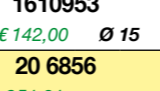
Products to be used exclusively for racing in places specially designed for such activity according to the regulations of the competent sporting authorities. We accept no liability resulting from improper use.

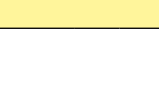
Prices EXCL. TAX

		PEUGEOT							
		103 RCX	103 SP [104 -105] - VOGUE	103 SPX	ADVENGER	FOX	HOLLYWOOD	XP	XP
		50	50 2T	50	50	50	50	50 2T	50 2T
	-	-	-	-	-	-	-	-	-
	31 6746 € 185,50 Ø 40	31 6746 € 185,50 Ø 40	31 6746 € 185,50 Ø 40	-	-	-	-	-	-
	38 4692 € 37,11	38 4692 € 37,11	38 4692 € 37,11	-	-	-	-	-	-
	38 4734 € 29,10	38 4734 € 29,10	38 4734 € 29,10	-	-	-	-	-	-
	31 8394 € 181,55	31 8394 € 181,55	31 8394 € 181,55	-	-	-	-	-	-
	31 8393 € 223,00	31 8393 € 223,00	31 8393 € 223,00	31 8393 € 223,00	-	31 8393 € 223,00	31 8393 € 223,00	31 8393 € 223,00	31 8393 € 223,00
	31 8388 € 185,50	31 8388 € 185,50	31 8388 € 185,50	-	31 8388 € 185,50	-	-	-	-
	38 5337 € 40,70	38 5337 € 40,70	38 5337 € 40,70	-	-	-	-	-	-
	38 4735 € 36,51	38 4735 € 36,51	38 4735 € 36,51	-	38 4735 € 36,51	-	-	-	-
	31 8384 € 120,00	31 8384 € 120,00	31 8384 € 120,00	-	31 8384 € 120,00	-	-	-	-
	-	-	-	-	-	-	-	-	-
	51 7123 € 58,71	51 7160 € 118,00	51 7123 € 58,71	51 7160 € 118,00	51 7073 € 58,71	51 7160 € 118,00	51 7160 € 118,00	51 7160 € 118,00	51 7160 € 118,00
	61 7220 € 12,90	61 7219 € 12,90	61 7220 € 12,90	61 7219 € 12,90	61 7214 € 22,47	61 7219 € 12,90	61 7219 € 12,90	61 7219 € 12,90	61 7219 € 12,90
	66 7147.40 € 3,52 gr.02,8	66 7143.40 € 5,75 gr.04	66 7147.40 € 3,52 gr.02,8	66 7143.40 € 5,75 gr.04	66 9823.M0 € 9,98 gr.07	66 7143.40 € 5,75 gr.04	66 7143.40 € 5,75 gr.04	66 7143.40 € 5,75 gr.04	66 7143.40 € 5,75 gr.04
	-	-	-	-	29 7042.Y0 € 5,91	-	-	-	-
	-	-	-	-	29 7043.R0 € 5,91	-	-	-	-
	51 1887 € 180,00	51 1885 € 154,00	51 1887 € 180,00	51 1885 € 154,00	-	51 1885 € 154,00	51 1885 € 154,00	51 1885 € 154,00	51 1885 € 154,00
	-	-	-	-	-	-	-	-	-
	-	51 1886 € 170,00	-	51 1886 € 170,00	-	51 1886 € 170,00	51 1886 € 170,00	51 1886 € 170,00	51 1886 € 170,00
	-	-	-	-	-	-	-	-	-
	57 6548 € 179,00	57 5208 € 179,00	57 6548 € 179,00	-	-	-	-	-	-
	A02045 € 37,40	A02045 € 37,40	A02045 € 37,40	-	-	-	-	-	-
	72 5741 € 86,24	72 5741 € 86,24	72 5741 € 86,24	-	-	-	-	-	-
	72 5742 € 86,24	72 5742 € 86,24	72 5742 € 86,24	-	-	-	-	-	-
	1610953 € 142,00 Ø 15	1610930 € 148,61 Ø 19	1610953 € 142,00 Ø 15	-	1611018 € 195,15 Ø 19	-	-	-	-
	20 6856 € 51,81	20 5037 € 55,00	20 6856 € 51,81	-	-	-	-	-	-
	20 6436 € 51,81	20 5039 € 51,81	20 6436 € 51,81	20 6138 € 63,27	-	20 6138 € 63,27	20 6138 € 63,27	20 6138 € 63,27	20 6138 € 63,27
	27 2356.C0 € 18,83 VL1	27 2356.C0 € 18,83 VL1	27 2356.C0 € 18,83 VL1	-	-	-	-	-	-
	-	-	-	-	67 6458 € 65,00 z 16/32	-	-	-	-

MBK - PEUGEOT

MALOSSİ

Aluminium CYLINDER Ø 45

ALUMINIUM CYLINDER

- Cylinders obtained by gravity die-casting in permanent steel moulds.
- Material: hardened and tempered high silicon content primary aluminium alloy.
- Machining: on numerically controlled high precision machine tools.
- Cylinder liner with silicon carbide metal-spray coating on a galvanic nickel matrix, cross-honed with passes with diamonds for very tight tolerances.
- Recalculated and increased heat exchange surfaces.
- Exhaust and transfer ports designed and tested for maximum thermodynamic performance.
- Dimensional and surface finish quality control.
- Cylinder and piston selected for a fit of 0.005 mm.
- Checking of all the seals carried out.

PISTON

- Material: special aluminium alloy with high silicon content and low thermal expansion.
- Machining: on numerically controlled machine tools.
- Lightened and strengthened.
- Heat exchange surfaces increased.

PISTON RINGS

- Piston rings in very strong modular cast iron with ground, wear-resistant, hard chrome metal-spray coating on the contact surface.

31 3013 € 220,00

 MBK 51 V - MAGNUM - PASSION -
 RACING 50 (AV 10) - ROCK 50

MALOSSİ

Aluminium H₂O CYLINDER KIT Ø 39

31 5477 € 225,00

 MBK 51 V - MAGNUM - PASSION -
 RACING 50 (AV 10) - ROCK 50

FEATURES

- Bore 39 mm
- Displacement 50 cc
- Compression ratio 11,8:1.
- Cylinder made of silicon-aluminium primary alloy.
 - Timing system by six cylinder inner holes.
- Cylinder liner with special hard chromium insert.
- Piston with extra-light structure and inner-finned cap.

MALOSSİ

Cast-iron CYLINDER Ø 45,5

Malossi cast iron thermal units, the first and simplest step to modifying your motorcycl's engine, are the best choice for continued use of the exhaust system of an approved series or type.

For these thermal units, the elevated feature of durability of cast iron is combined with the almost manically high quality standards of Malossi, one of the few companies to demand the most from even this class of thermal units. Into this is inserted the most rigid selections for the joining of the cylinder and the piston, strictly maintained within a range of 20 microns maximum of tolerance.

31 8384 € 120,00
HONDA WALLAROO 50

PEUGEOT FOX - 103 RCX - 103 SPX 50

103 SP [104 -105] - VOGUE 50 2T



CAST-IRON CYLINDER

- Material: special self-lubricating, wear-resistant, highly refined cast iron alloys, obtained by Shell Moulding gravity die-casting.
- Machining: on numerically controlled high precision machine tools.
- Recalculated and increased heat exchange surfaces.
- Exhaust and transfer ports designed and tuned for maximum thermodynamic performance.
- Dimensional and surface finish quality control.
- Cylinder and piston selected for a 100% fit of 0.010-0.005 mm.
- Checking of all the seals carried out.

Prices EXCL. TAX

MALOSSİ

Aluminium CYLINDERS

31 6746 - Ø 40 - € 185,50
PEUGEOT 103 RCX 50

103 SP [104 -105] - VOGUE 50 2T

103 SPX 50

31 8388 - Ø 45,5 - € 185,50
HONDA WALLAROO 50

PEUGEOT FOX - 103 RCX - 103 SPX 50

103 SP [104 -105] - VOGUE 50 2T



HEAD Ø 45,5

38 4735 € 36,51

ONLY for Malossi CYLINDERS 31 8384 - 31 8388

HONDA WALLAROO 50

PEUGEOT FOX - 103 RCX - 103 SPX 50

103 SP [104 -105] - VOGUE 50 2T



Mopeds PEUGEOT 50	Heads					
	With decompressor Ø 40		Without decompressor Ø 40		With decompressor Ø 45,5	
	Code	Price	Code	Price	Code	Price
103 RCX	38 4692	€ 37,11	38 4734	€ 29,10	38 5337	€ 40,70
103 SP [104 -105] - VOGUE 2T	38 4692	€ 37,11	38 4734	€ 29,10	38 5337	€ 40,70
103 SPX	38 4692	€ 37,11	38 4734	€ 29,10	38 5337	€ 40,70

MALOSSI

Aluminium H₂O CYLINDER KIT

Malossi aluminum cylinder kits are perfect for those who demand more performance from their moped, without sacrificing installation ease or ending up with invasive modifications that require excessive tuning.

The technical features of **aluminum, which allows greater compression and power to be obtained**, make these cylinders decidedly more advanced than cast-iron versions.



Mopeds	Without decompressor Ø 45,5		With decompressor Ø 45,5	
	Code	Price	Code	Price
PEUGEOT 50				
ADVENGER	31 8393	€ 223,00	---	---
HOLLYWOOD	31 8393	€ 223,00	---	---
103 RCX	31 8393	€ 223,00	31 8394	€ 181,55
103 SP [104 -105] - VOGUE 2T	31 8393	€ 223,00	31 8394	€ 181,55
103 SPX	31 8393	€ 223,00	31 8394	€ 181,55
XP 2T LC	31 8393	€ 223,00	---	---
XP 2T	31 8393	€ 223,00	---	---

Prices EXCL. TAX

• The picture refers to art. 31 8393

MALOSSI

CRANKCASE KIT

57 5208 € 179,00

PEUGEOT 103 SP [104-105]

VOGUE 50 2T

57 6548 € 179,00

PEUGEOT 103 RCX

103 SPX 50



Reinforced engine crankcase fixed to the integrated frame and intake via a high-flow rate valve. New, ultra-elegant design, large size, compact, with lightweight, but solid structure. Obtained by fusion pressure of special aluminium alloy with high mechanical resistant and machined on high-precision CNC controlled machinery.

With this project, Malossi has created a truly universal crankcase, which is perfectly compatible with the original one, and which offers two possibilities: to obtain an engine with an excellent, sporting performance using Peugeot parts or a special, authentic Malossi engine, using Malossi parts (crankshaft, thermal unit, fuel and exhaust system)

The crankcases have four carbon fibre petals, a PHBG 17-21 intake manifold, variator cover support, gasket set, fastening screws and everything required for assembly.



FOR VEHICLES WITH CLUTCH



51 1887 € 180,00
 PEUGEOT 103 RCX - 103 SPX 50

51 1885 € 154,00
 PEUGEOT ADVENGER - HOLLYWOOD -
 103 SP [104 -105] - VOGUE 50 2T
 XP 50 2T LC - XP 50 2T

FOR VEHICLES WITH CLUTCH (reversed fitting)



51 7723 € 180,00
 MBK 51 V - MAGNUM -
 PASSION - 50 (AV 10)
 ROCK 50

FOR VEHICLES WITHOUT CLUTCH



51 6839 € 170,00
 MBK 51 V - MAGNUM -
 PASSION - 50 (AV 10)
 ROCK 50

51 1886 € 170,00
 PEUGEOT ADVENGER - HOLLYWOOD -
 103 SP [104 -105] - VOGUE 50 2T
 XP 50 2T LC - XP 50 2T

FOR VEHICLES WITHOUT CLUTCH (for original variator cover)



51 6921 € 180,00
 MBK 51 V - MAGNUM -
 PASSION - 50 (AV 10)
 ROCK 50

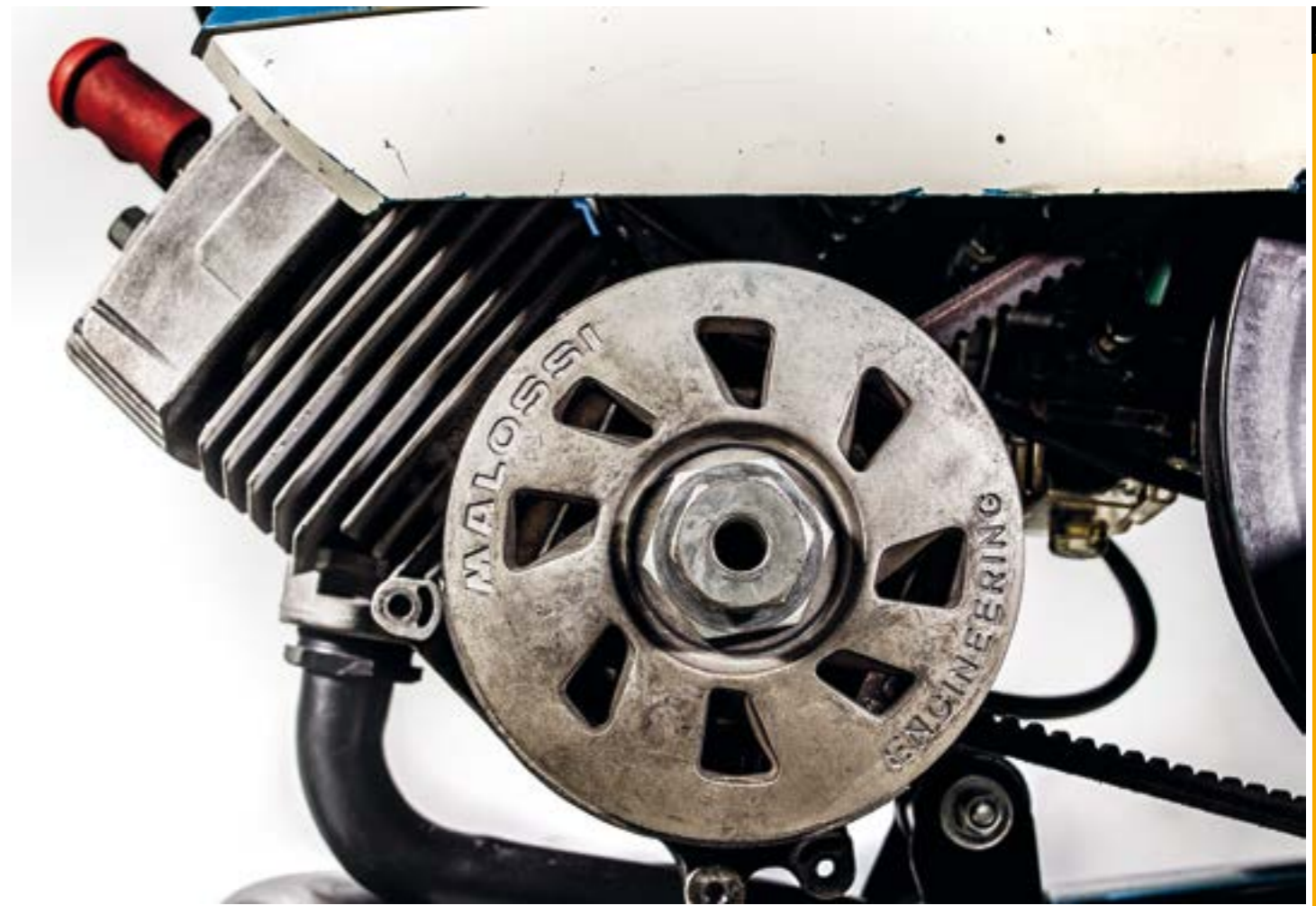

VAR PLUS

51 6798 € 33,12
 MBK 51 V - MAGNUM -
 PASSION -
 RACING 50 (AV 10)
 ROCK 50

















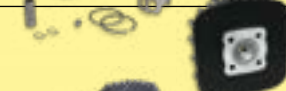

Products to be used exclusively for racing in places specially designed for such activity according to the regulations of the competent sporting authorities. We accept no liability resulting from improper use.

MALOSSI





Automatic Mopeds

with ENGINE 

		HONDA			
		CAMINO	MTX (automatico)	NSR (automatico)	PX
		50 	50 	50 	50 
	CYLINDER CAST-IRON	Ø 45,5 31 3642 € 149,46	-	-	31 3642 € 149,46
	CYLINDER ALUMINIUM	Ø 44,5 - 45,5	31 4260 € 203,00 Ø 44,5	31 4260 € 203,00 Ø 44,5	-
	HEAD	Ø 44,5 - 45,5	-	-	-
	CYLINDER ALUMINIUM	Ø 42	-	-	-
	MULTIVAR VARIATOR		51 7134 € 67,00	51 7134 € 67,00	-
	X SPECIAL BELT BELT		-	-	-
	HTRoll ROLLERS FOR MULTIVAR		66 9823.H0 € 9,98 gr.04,7	66 9823.H0 € 9,98 gr.04,7	-
	VARIATOR ADJUSTER SPRING SPORT / MHR		29 7042.Y0 € 5,91 29 7043.R0 € 5,91	29 7042.Y0 € 5,91 29 7043.R0 € 5,91	29 7042.Y0 € 5,91 29 7043.R0 € 5,91
	TORSION CONTROLLER		-	-	-
	CARBURETTOR KIT	PHBG	1610944 € 150,66 Ø 21	1610898 € 109,98 Ø 21	1610898 € 109,98 Ø 21
		SHA 15/15	-	-	-
		SHA 16/16	-	-	-
	GEARS HTQ PRIMARY		67 6416 € 68,34 z 13/35	-	67 6419 € 74,88 z 13/35
	PINION		-	61 4695B € 5,12 z 17	61 4695B € 5,12 z 17
	BRAKE PADS ORGANIC BRAKE PADS	FRONT	-	-	6215857 € 8,84 1993->94



Prices EXCL. TAX

HONDA	PUCH	SUZUKI	YAMAHA
WALLAROO	MAXI	TS ER 21 XAP (automatico)	DT MX (automatico)
50 	50 	50 2T 	50 
31 8384 € 120,00	-	-	-
31 8388 € 185,50 Ø 45,5	-	31 3194 € 174,75 Ø 45,5	31 3058 € 220,00 Ø 44,5
38 4735 € 36,51 Ø 45,5	-	-	38 3470 € 56,68 Ø 44,5
-	31 2621 € 224,00	-	-
51 7073 € 58,71	-	-	51 7140 € 58,00
61 7214 € 22,47	-	-	-
66 9823.M0 € 9,98 gr.07	-	-	66 7147.40 € 3,52 gr.02,8
29 7042.Y0 € 5,91 29 7043.R0 € 5,91	-	-	-
2512828 € 4,45	-	-	-
1610987 € 165,89 Ø 17	-	-	1610444 € 125,73 Ø 19,5
-	1610352 € 79,26	-	-
-	1610992 € 83,43	-	-
67 6458 € 65,00 z 16/32	-	-	-
-	61 2499B € 9,12 z 17	-	-
-	-	-	-



Products to be used exclusively for racing in places specially designed for such activity according to the regulations of the competent sporting authorities. We accept no liability resulting from improper use.

2T Engine oil

76 8231S

2T OIL SPORT ENGINE (SAE 20W-30)

Specifications : API TC - JASO FC

[6] Bottles of 1 L € 72,05

It is a special semi-synthetic lubricating oil of high quality tested for both liquid and air cooled racing engines, with or without mixer. It is suitable for any 2-strokes engines and it offers very high performances. 7.1 is a lubricating oil composed of ash-free additives and it is able to guarantee the maximum cleanness of the involved components, absence of deposits, substantial reduction of smokes.



7616711

2T OIL TOP RACING FULL SYNT (SAE 40)

Specifications : API TC - JASO FC - JSO L-EGD

[6] Bottles of 1 L € 156,46

Developed exclusively for racing 2-stroke engines, 7.1 TOP RACING is formulated using synthetic esters that ensure exceptional anti-wear properties, reducing internal friction and guaranteeing consistent performance over time. 7.1 TOP RACING ensures superior load-resistance and cleanliness characteristics for racing engines, requirements necessary for the full development of power even with very rich oil-gasoline (oil-petrol) blends. 7.1 TOP RACING is particularly resistant to sticking piston rings and the formation of residues on spark plugs, to help the engine to develop maximum power for the whole duration of the race. The product forms a tough film between the cylinder, piston and piston ring, prolonging the life of the engine. It can be mixed with any type of gasoline (petrol), in every season of the year, without any problem of mixing and stability of the mixture.



76 8230S

2T OIL RACING FULL SYNT (SAE 20W-30)

Specifications : API TC - JASO FC

[6] Bottles of 1 L € 104,84

Thanks to the experience Malossi gained in races, an innovative product for 2-stroke engines with high performance was born. 7.1 is a completely synthetic lubricating oil obtained with a high quality synthetic base and carefully selected additives to guarantee the highest performance without neglecting the protection of the environment. It has been designed for racing vehicles with or without separate mixer.

7.1 guarantees:

- High engine efficiency
- Reduction of the wear of the involved components and thereby a longer life of the vehicle.
- Minimum formation of incrustations and deposits in the combustion chamber and at the exhaust.
- It avoids piston rings to be stuck together and therefore it guarantees the perfect tightness of the compression for long.
- Substantial reductions of exhaust smokes.



7.1

7613471

RACING GEAR OIL FULL SYNT (SAE 75W-90)

[12] Bottles of 0,25 L € 56,07

GEAR OIL

Synthetic gear lubricant for racing scooters and bikes. It has high natural viscosity index and excellent shear strength, as well as higher load resistance. The synthetic materials used for this formulation have an oxidation stability up to 3 times higher than that of traditional mineral oils, prolonging the effective life of the lubricant, even if subjected to extreme working conditions. Beside this, the lower friction value leads to reduced pitting and wear of the gear teeth. Its excellent E.P. features and its low viscosity help in protecting the gearbox components.



7613469

SPORT GEAR OIL (SAE 80W-90)

[12] Bottles of 0,25 L € 51,08

GEAR OIL

Advanced specification gear and transmission oil. It contains E.P. additives which protect transmission parts even under severe shock load conditions and give outstanding long life wear resistance. By reducing viscous drag and friction, the product ensures smooth and slick gear changes, reducing wear and transmission power losses. The unique thermally stable construction of these lubricants maintains higher protection in all climates. This product can be used in wet clutch systems. It grants higher performances and it prevents the overheating of the gear parts in such a better way compared to the traditional mineral oils.



suitable for all vehicles

The importance of grip is well known since the mists of time. Man has always strived to create safer and more effective grips on tools and weapons, without neglecting to personalise them, sometimes embellished with precious materials.

At last today, your motorcycle too can have something special: Malossi took care of it!

A firm grip is never missing, palm and fingers grasp the grip to convey riding commands, sometimes gently, sometimes with great force, according to your temperament or to your mood, and the engine, producing a sound that is music to the ears of every rider that lives for the ride, responds to your input for performance and carries you into the wind.

Malossi grips have no competition when concerning your motorcycle ride: they are safe, anatomically comfortable, indestructible, and stylish too, because the care for aesthetics has never been of secondary importance to us!



Malossi GRIPS PAIR

Technical Characteristics :

Without side fastening
6914059.RO € 21,00

red



With side fastening
6914060.RO € 21,00

red



Without side fastening
6914059.YO € 21,00

yellow



With side fastening
6914060.YO € 21,00

yellow



- dual compound, dual hardness, dual colour;
- micro-pyramid pattern provides firm safe grip;
- chassis in semi-rigid torque-limited elastomer;
- top-quality material, special anti-allergy material;
- resistant to atmospheric agents, UV rays, ozone;
- anatomical shape and structure;
- two grooves for steel wire give extra security;
- length 125 mm, standard 22/24 mm diameter .
- With folder of black and silver Malossi mini stickers dimensions 11x16,8 cm ([3314154](#))



GRIPS PAIR with Malossi TRIBAL logo

Technical Characteristics :

Without side fastening
6914574.WO € 24,00

white



With side fastening
6914575.WO € 24,00

black



Without side fastening
6914574.BO € 24,00

white



With side fastening
6914575.BO € 24,00

black



- Top quality material
- Resistant to atmospheric conditions, UV rays, Ozone
- Inner flange reinforced for hand support and to eliminate vibrations
- UP is marked at the ends of the grip to designate the correct orientation upon installation
- Anatomically designed for comfort and strength
- With folder of color Malossi stickers dimensions 11x16,8 cm ([3314153](#))



Products to be used exclusively for racing in places specially designed for such activity according to the regulations of the competent sporting authorities. We accept no liability resulting from improper use.

MALOSSİ JET HELMET

Light and comfortable jet helmet with large visor for best protection.

4115640.B(*) € 81,00

BLACK BRIGHT



4115640.W(*) € 81,00

WHITE BRIGHT



Technical features

- Polycarbonate outer shell
- EPS dual-density inner shell
- Micrometric buckle for the chinstrap closing
- Anti-scratch visor with quick release system
- Fully removable and washable ergonomic liner in hypoallergenic fabric
- Homologated according to European Law CE 22 05



The new visors are now available

SMOKE AVIATOR VISOR

4116682BF € 17,00



CLEAR LONG VISOR

4116683BN € 20,00



Following sizes available:

4115640.B2 tg. XS				
ATTENTION: When ordering, please remember to attach the code number that represents the desired size to the part number. See example above in RED.				
Code(*)	Code(*)	Size	Head circumference (cm)	Weight
4115640.B2	4115640.W2	XS	53/54	1050 gr
4115640.B3	4115640.W3	S	55/56	1050 gr
4115640.B4	4115640.W4	M	57/58	1050 gr
4115640.B5	4115640.W5	L	59/60	1050 gr
4115640.B6	4115640.W6	XL	61/62	1050 gr

GRIFFE

4213415.B0 € 3,87
2 PLUGS for TYRE INNER TUBE VALVE



New colors!



Malossi work gloves

4117727.(*)
€ 30,00

94% Polyester, 6% Spandex



4117727.30	tg. 8 - SMALL			
ATTENTION:	When ordering, please remember to attach the code number that represents the desired size to the part number. See example above in RED.			
(*)	.30	.40	.50	.60
	8 - SMALL	9 - MEDIUM	10 - LARGE	11 - XL

25 Folders of matched stickers
24,7x35 cm **33 9780.16 € 78,70**



Products to be used exclusively for racing in places specially designed for such activity according to the regulations of the competent sporting authorities. We accept no liability resulting from improper use.

“ Sometimes a winner is only a dreamer who hasn't given up ”
 (Nelson Mandela)

Henry Favre
for Malossi Gas
in Scotland
with the Ciao
Aosta
Isle of Skye Scotland
Km 2523



MALOSSIGAS
 Great Adventure Series



MALOSSSI
CAMP



MALOSSSI



CAMP

